

S3006P/3008P/3010P

PUSH-AROUND MINI SCISSOR LIFTS

SCISSOR LIFT

Hire Centre



- Lightweight and compact
- Easily passes through a standard doorway
- No outriggers or stabilisers required
- Durable design for tough site conditions
- Proven benefits over other low level access products:
 - better job site productivity
 - safer and more convenient working conditions
 - better return on investment (ROI) for rental/hire companies

snorkel

www.elevatedaccess.co.nz

S3006P/3008P/3010P

PUSH-AROUND MINI SCISSOR LIFTS

S3006P 3008P/3010P

DIMENSIONS	S3006P	S3008P	S3010P
Max. working height	4.0m	4.5m	5.0m
Max. platform height (A)	2.0m	2.5m	3.0m
Platform capacity (SWL)	240kg	240kg	240kg
Overall width (B)	0.75m	0.75m	0.75m
Overall length (C)	1.3m	1.3m	1.3m
Stowed height (D)	1.7m	1.8m	1.8m

PERFORMANCE

Max. wind speed	0m/s	0m/s	0m/s
Raise/lower time	8/14 sec	13/17 sec	19/26 sec

POWER

Power source	12 volt DC battery
Charger	Built in multi-voltage (90V - 240V)

WEIGHT

Weight	310kg	350kg	370kg
--------	-------	-------	-------

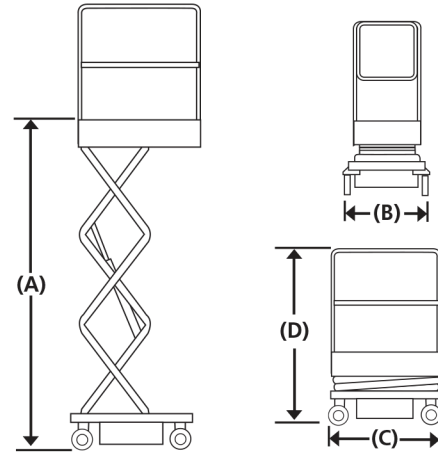

STANDARD FEATURES

- Auto brake system
- Tilt sensor
- Battery charge indicator
- Saloon gates
- Forklift points
- Emergency lowering
- Non-marking coasters
- Slide-out service trays
- 2 year parts & labour, 5 year structural warranty
- CE approved

OPTIONS

- Special paint colours

WORKING HEIGHT

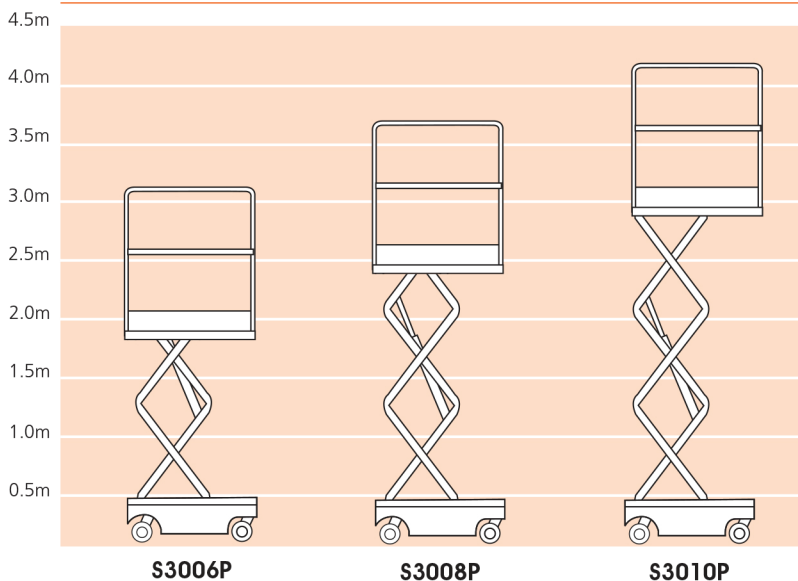

SCISSOR LIFT
Hire Centre



www.hirescissorlift.co.nz

Email us at: sales@hirescissorlift.co.nz

We look forward to helping you!